

## RFC Motor Control Gives Unidrive SP a Major Advantage

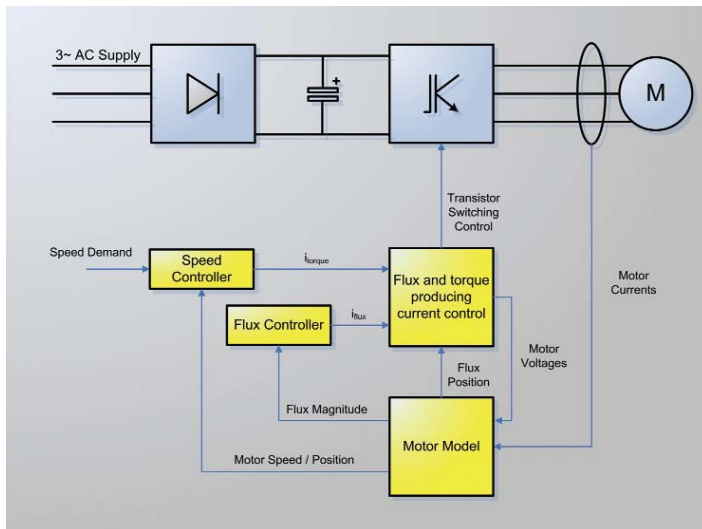

**Rotor Flux Control (RFC) is seen as a major advantage in applications where a combination of dynamic performance, stability and speed accuracy are required *without* encoder feedback and where low audible noise is important. The advanced method of open-loop speed control devised at Control Techniques is a standard feature on its flag-ship range of AC drives, Unidrive SP.**

“Control Techniques is recognised as a world leader in variable speed drive technology,” says Product Manager Richard Smith. “RFC, provides a simulated speed feedback that gives excellent speed accuracy; certainly the best results without actually having the cost of direct feedback from an encoder.”

Many £ millions have been spent by the drives industry trying to develop the perfect control algorithm to achieve accurate and dynamic control of a standard AC induction motor without measuring its speed – yet, to date, closed-loop control, with its extra costs of wiring and a costly encoder, has been the only choice for some applications.

Several methods of open loop control exist; V/F is the simplest and lowest cost to implement, however the speed of the motor changes significantly with load and temperature so that good speed holding and low speed operation is impossible.

Open-loop vector control, which models some aspects of the motor, is better, giving good speed holding, but only

moderate dynamic performance. Direct Torque Control (DTC) offers improved dynamic performance, but does not allow the user to modify the switching frequency resulting in significant audible noise from the motor plus additional motor losses.

RFC, addresses all of these drawbacks, using a simple, yet accurate, mathematical motor model, to calculate a simulated speed and position feedback, allowing the loop to be closed without the need to physically mount and wire an encoder. The simplicity of the algorithm allows the calculations to be performed synchronously with the speed and current loops within the drive, resulting in a characteristic performance that is dynamic, with excellent speed accuracy and a stable operation even with troublesome light loads.

RFC control delivers full torque in less than 0.5ms, (compared with four times this for DTC) significantly increasing the dynamic performance of the drive and motor and greatly extending the bandwidth of the system.

Commissioning is simplicity itself, with the drive able to measure many of the key parameters required; the others being obtained directly from the motor’s rating plate. What’s more, the switching frequency is selectable, making the drive suitable for applications where low audible drive noise is important such as lifts.

“RFC is not a solution to every application,” adds Richard Smith. “Demanding systems where accurate speed and torque control is required down to zero speed, will still require feedback devices. It does however allow open loop drives to be used in more applications where, in the past, only a closed loop drive would be able to perform. And it’s a no-cost feature on Unidrive SP, allowing the user to select the best control method for their application, including V/F, open-loop vector, RFC and true closed-loop control.”

### KEY BENEFITS

- BEST DYNAMIC PERFORMANCE WITHOUT ENCODER FEEDBACK
- EXCELLENT SPEED ACCURACY
- FULL TORQUE IN LESS THAN 0.5MS
- STABLE OPERATION WITH LARGE MOTORS ON LIGHT LOADS



For the full press release please visit [www.controltechniques.com](http://www.controltechniques.com)

